

**DR-2212, DR-2212-P,
DR-2212-R, DR-2212-R-P****DR-2512, DR-2512-P
DR-2512-R, DR-2512-R-P****Berührungsloser Drehmomentsensor, rotierend
Contactless Torque Sensor, rotating**

- Nenndrehmoment von 0,1 N·m ... 20000 N·m -
Nominal torque from 0.1 N·m ... 20000 N·m
- Genauigkeitsklasse optional 0,05% - *Accuracy class optional 0.05%*
- Aktiver Ausgang ±5V (optional ±10V) - *Active output ±5V (optional ±10V)*
- Drehzahl bis 15000 min⁻¹ - *Speed up to 15000 min⁻¹*
- Integrierte Drehzahl-/Drehwinkelmessung optional -
Integrated speed/angle measurement optional
- Sehr kurze axiale Baulänge - *Very short axial length*
- Hohe Drehsteifigkeit - *High torsional stiffness*
- Zuverlässig und robust - *Reliable and durable*
- Einfache Handhabung und Montage - *Simple handling and assembly*
- Sonderausführungen auf Anfrage - *Special versions on request*

**Berührungsloser Drehmomentsensor, rotierend
Contactless Torque Sensor, rotating**

- Nenndrehmoment von 0,1 N·m ... 20000 N·m -
Nominal torque from 0.1 N·m ... 20000 N·m
- Genauigkeitsklasse optional 0,05% - *Accuracy class optional 0.05%*
- Digitaler Ausgang RS485 - *Digital output RS485*
- Drehzahl bis 15000 min⁻¹ - *Speed up to 15000 min⁻¹*
- Integrierte Drehzahl-/Drehwinkelmessung optional -
Integrated speed/angle measurement optional
- Sehr kurze axiale Baulänge - *Very short axial length*
- Hohe Drehsteifigkeit - *High torsional stiffness*
- Zuverlässig und robust - *Reliable and durable*
- Einfache Handhabung und Montage - *Simple handling and assembly*
- Sonderausführungen auf Anfrage - *Special versions on request*
- Auto-Identifikation von: Messbereich, Serien- Nr.
Kalibrierdatum - *Auto identification of: measuring range, serial number, date of calibration*

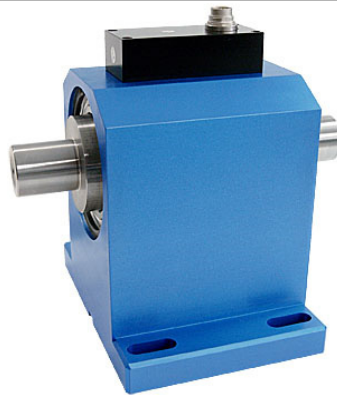

Diese Sensoren haben eine berührungslose und digitale Signalübertragung von Rotor zu Stator, also ohne Signalverfälschung und wartungsfrei.

These sensors have a contactless and digital signal transmission from rotor to stator, which means no signal falsification and maintenance-free.

Technische Daten - Specifications

Artikel-Nr. Article-No. DR-2212	Artikel-Nr. Article-No. DR-2212-P ¹	Nennmoment Nominal Torque [N·m]	Grenzdrehzahl Limit Speed [min ⁻¹]	Federkonstante Springrate [N·m/rad]	Massen- trägheits- moment Mass Moment of Inertia [kg·m ²]		Grenzlängskraft Limit Thrust Load [N]	Grenzquerkraft Limit Shear Force [N]
					Antriebsseite Drive Side	Messseite Test Side		
103819	115628	0,1	15000	1,8E+01	1,9E-06	2,8E-07	30	0,9
103820	115629	0,2	15000	1,8E+01	1,9E-06	2,8E-07	30	1,2
102921	115630	0,5	15000	1,2E+02	1,9E-06	2,8E-07	30	2,9
102866	115631	1	15000	1,2E+02	2,0E-06	2,8E-07	30	2,9
102437	115632	2	12000	4,4E+02	1,0E-05	8,1E-06	62	8,5
102922	110436	5	12000	4,4E+02	1,0E-05	8,1E-06	62	8,5
102794	115641	10	12000	1,7E+03	1,0E-05	8,2E-06	62	28
102909	109963	20	12000	4,5E+03	1,2E-05	9,9E-06	62	43
104212	111072	30	12000	4,5E+03	1,2E-05	9,9E-06	62	65
102457	111230	50	12000	8,5E+03	1,3E-05	1,2E-05	62	64
102836	110435	100	12000	8,4E+03	1,3E-05	1,2E-05	62	64
103337	109961	200	7000	9,2E+04	1,3E-03	8,0E-04	760	350
103602	112509	500	7000	9,2E+04	1,3E-03	8,0E-04	760	420
103822	115668	1000	7000	3,1E+05	1,6E-03	1,1E-03	760	800
103821	112659	2000	5500	7,2E+05	5,3E-03	4,3E-03	1100	860
103709	111182	5000	5500	8,0E+05	5,4E-03	4,3E-03	1100	860
105485	113347	10000	3500	3,1E+06	4,0E-02	3,7E-02	2800	2300
105486	113348	20000	3500	3,7E+06	4,0E-02	3,8E-02	2800	2300
Artikel-Nr. Article-No. DR-2212-R ³	Artikel-Nr. Article-No. DR-2212-R-P	Nennmoment Nominal Torque [N·m]	Grenzdrehzahl Limit Speed [min ⁻¹]	Federkonstante Springrate [N·m/rad]	Massen- trägheits- moment Mass Moment of Inertia [kg·m ²]		Grenzlängskraft Limit Thrust Load [N]	Grenzquerkraft Limit Shear Force [N]
					Antriebsseite Drive Side	Messseite Test Side		
108693	115617	0,1	15000	1,8E+01	1,9E-06	2,8E-07	30	0,9
108694	115618	0,2	15000	1,8E+01	1,9E-06	2,8E-07	30	1,2
108695	115619	0,5	15000	1,2E+02	1,9E-06	2,8E-07	30	2,9
108696	113309	1	15000	1,2E+02	2,0E-06	2,8E-07	30	2,9
108697	115620	2	12000	4,4E+02	1,0E-05	8,1E-06	62	8,5
108698	115621	5	12000	4,4E+02	1,0E-05	8,1E-06	62	8,5
108699	115683	10	12000	1,7E+03	1,0E-05	8,2E-06	62	28
108701	110886	20	12000	4,5E+03	1,2E-05	9,9E-06	62	43
108819	110437	30	12000	4,5E+03	1,2E-05	9,9E-06	62	65
108702	110083	50	12000	8,5E+03	1,3E-05	1,2E-05	62	64
108703	111271	100	12000	8,4E+03	1,3E-05	1,2E-05	62	64
108704	110438	200	7000	9,2E+04	1,3E-03	8,0E-04	760	350
108705	111617	500	7000	9,2E+04	1,3E-03	8,0E-04	760	420
108706	115622	1000	7000	3,1E+05	1,6E-03	1,1E-03	760	800

¹ Ausführung „-P“ Passfeder - Version „-P“ feather key

² Ohne Option Drehzahl-/Drehwinkelmessung - Without option speed/angle measurement

³ Ausführung „-R“ Genauigkeitsklasse 0,2% v. Endwert - Version „-R“ accuracy class 0.2% f. scale

Technische Daten - Specifications

Artikel-Nr. Article-No. DR-2512	Artikel-Nr. Article-No. DR-2512-P ⁴	Nennmoment Nominal Torque [N·m]	Grenzdrehzahl Limit Speed [min ⁻¹]	Federkonstante Springrate [N·m/rad]	Massen- trägheits- moment Mass Moment of Inertia [kg·m ²] ⁵		Grenzlängskraft Limit Thrust Load [N]	Grenzquerkraft Limit Shear Force [N]
					Antriebsseite Drive Side	Messseite Test Side		
104183	115698	0,1	15000	1,8E+01	1,9E-06	2,8E-07	30	0,9
104184	115699	0,2	15000	1,8E+01	1,9E-06	2,8E-07	30	1,2
104185	115700	0,5	15000	1,2E+02	1,9E-06	2,8E-07	30	2,9
104186	115701	1	15000	1,2E+02	2,0E-06	2,8E-07	30	2,9
104187	115702	2	12000	4,4E+02	1,0E-05	8,1E-06	62	8,5
104188	115703	5	12000	4,4E+02	1,0E-05	8,1E-06	62	8,5
104189	115704	10	12000	1,7E+03	1,0E-05	8,2E-06	62	28
104191	115705	20	12000	4,5E+03	1,2E-05	9,9E-06	62	43
104213	115706	30	12000	4,5E+03	1,2E-05	9,9E-06	62	65
104192	115707	50	12000	8,5E+03	1,3E-05	1,2E-05	62	64
104193	110642	100	12000	8,4E+03	1,3E-05	1,2E-05	62	64
104194	115708	200	7000	9,2E+04	1,3E-03	8,0E-04	760	350
104195	114190	500	7000	9,2E+04	1,3E-03	8,0E-04	760	420
104196	115709	1000	7000	3,1E+05	1,6E-03	1,1E-03	760	800
104197	115710	2000	5500	7,2E+05	5,3E-03	4,3E-03	1100	860
104198	115711	5000	5500	8,0E+05	5,4E-03	4,3E-03	1100	860
107499	115712	10000	3500	3,1E+06	4,0E-02	3,7E-02	2800	2300
109686	115713	20000	3500	3,7E+06	4,0E-02	3,8E-02	2800	2300
Artikel-Nr. Article-No. DR-2512-R ⁶	Artikel-Nr. Article-No. DR-2512-R-P	Nennmoment Nominal Torque [N·m]	Grenzdrehzahl Limit Speed [min ⁻¹]	Federkonstante Springrate [N·m/rad]	Massen- trägheits- moment Mass Moment of Inertia [kg·m ²]		Grenzlängskraft Limit Thrust Load [N]	Grenzquerkraft Limit Shear Force [N]
					Antriebsseite Drive Side	Messseite Test Side		
108723	115684	0,1	15000	1,8E+01	1,9E-06	2,8E-07	30	0,9
108724	115685	0,2	15000	1,8E+01	1,9E-06	2,8E-07	30	1,2
108725	115686	0,5	15000	1,2E+02	1,9E-06	2,8E-07	30	2,9
108726	115687	1	15000	1,2E+02	2,0E-06	2,8E-07	30	2,9
108727	115688	2	12000	4,4E+02	1,0E-05	8,1E-06	62	8,5
108728	115689	5	12000	4,4E+02	1,0E-05	8,1E-06	62	8,5
108729	115690	10	12000	1,7E+03	1,0E-05	8,2E-06	62	28
108731	113335	20	12000	4,5E+03	1,2E-05	9,9E-06	62	43
108820	115691	30	12000	4,5E+03	1,2E-05	9,9E-06	62	65
108732	110204	50	12000	8,5E+03	1,3E-05	1,2E-05	62	64
108733	115693	100	12000	8,4E+03	1,3E-05	1,2E-05	62	64
108734	115694	200	7000	9,2E+04	1,3E-03	8,0E-04	760	350
108735	115695	500	7000	9,2E+04	1,3E-03	8,0E-04	760	420
108736	115696	1000	7000	3,1E+05	1,6E-03	1,1E-03	760	800

⁴ Ausführung „-P“ Passfeder - Version „-P“ feather key

⁵ Ohne Option Drehzahl-/Drehwinkelmessung - Without option speed/angle measurement

⁶ Ausführung „-R“ Genauigkeitsklasse 0,2% v. Endwert - Version „-R“ accuracy class 0.2% f. scale

		DR-2212, DR-2212-P (DR-2212-R, DR-2212-R-P)	DR-2512, DR-2512-P (DR-2512-R, DR-2512-R-P)
Genauigkeitsklasse - <i>Accuracy class</i>	% v. E. - <i>f. s.</i>	0,1 (0,2)	
Reproduzierbarkeit - <i>Repeatability</i> (DIN 1319)	%	±0,02 (±0,04)	
Versorgung - <i>Supply voltage</i>	VDC	12 ... 28	
Stromaufnahme - <i>Current consumption</i>	mA	≤60	
Ausgangssignal - <i>Output signal</i>		±5V	±25000 Digits
Kontrollsignalaufschaltung - <i>Control signal excitation</i>	V	L <2,0; H >3,5	per Software
Messrate - <i>Sample rate</i>	kSample/s	10	5
Referenztemperatur - <i>Reference temperature</i>	°C	23	
Nenntemperaturbereich - <i>Nominal temperature range</i>	°C	5 ... 45	
Gebrauchstemperaturbereich - <i>Service temperature range</i>	°C	0 ... 60	
Lagerungstemperaturbereich - <i>Storage temperature range</i>	°C	-10 ... 70	
Temp. koef. des Kennwerts - <i>Temp. coeff. of sensitivity</i>	% v. E./K - <i>f. s./K</i>	±0,01 (±0,015)	
Temp. koef. des Nullsignals - <i>Temp. coeff. of zero signal</i>	% v. E./K - <i>f. s./K</i>	±0,02 (±0,03)	
Gebrauchsdrehmoment (statisch) - <i>Service torque (static)</i>	% v. E. - <i>f. s.</i>	150	
Grenzdrehmoment (statisch) - <i>Limit torque (static)</i>	% v. E. - <i>f. s.</i>	200	
Bruchdrehmoment (statisch) - <i>Ultimate torque (static)</i>	% v. E. - <i>f. s.</i>	>300	
Schwingbreite - <i>Bandwidth</i> (DIN 50100)	%	70 (Spitze - Spitze) - (<i>peak - peak</i>)	
Schutzart - <i>Level of protection</i> (DIN EN 60529)		IP50	
Elektrischer Anschluss - <i>Electrical connection</i>		12-polig Serie 581 - <i>12-pin series 581</i> ⁷	

Anschlussbelegung - Pin Connection

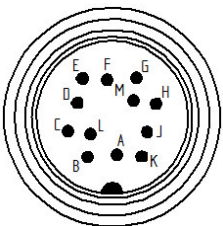
12-polig - 12-pin	DR-2212, DR-2212-R, DR-2212-P, DR-2212-R-P		
Pin A	NC	-	<p>Serie - Series 581</p>  <p>Draufsicht - Top view</p>
Pin B	Opt. Signal Winkel B - <i>Opt. Signal angle B</i>	5V TTL	
Pin C	Signal (+) - <i>Signal (+)</i>	±5V (±10V)	
Pin D	Signal (GND) - <i>Signal (GND)</i>	0V	
Pin E	Vers. (GND) - <i>Supply (GND)</i>	0V	
Pin F	Vers. (+) - <i>Supply (+)</i>	12 ... 28VDC	
Pin G	Opt. Signal Winkel A - <i>Opt. Signal angle A</i>	5V TTL	
Pin H	NC	-	
Pin J	NC	-	
Pin K	Kontrollsignal - <i>Control signal</i>	L <2,0V; H >3,5V	
Pin L	NC	-	
Pin M	Schirm - <i>Shield</i>	-	

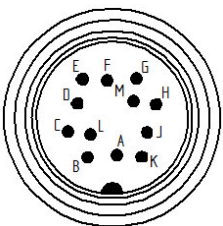
12-polig - 12-pin	DR-2512, DR-2512-R, DR-2512-P, DR-2512-R-P		
Pin A	NC	-	<p>Serie - Series 581</p>  <p>Draufsicht - Top view</p>
Pin B	NC	-	
Pin C	NC	-	
Pin D	NC	-	
Pin E	Vers. (GND) - <i>Supply (GND)</i>	0V	
Pin F	Vers. (+) - <i>Supply (+)</i>	12 ... 28VDC	
Pin G	NC	-	
Pin H	NC	-	
Pin J	RS485	RS485 (B)	
Pin K	NC	-	
Pin L	RS485	RS485 (A)	
Pin M	Schirm - <i>Shield</i>	-	

⁷ Kabeldose bei Erstausslieferung im Lieferumfang enthalten - *Female cable connector in scope of delivery at first delivery*

Optionen/ Zubehör - Options/ Accessories

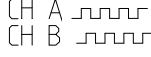
Artikel-Nr. - Article-No.	Bezeichnung - Description		
101695	Genauigkeitsklasse - Accuracy class	% v. E. - f. s.	0,05
103562	Ausgangssignal - Output signal	V	±10
101560 ⁸	Drehzahl-/Drehwinkelmessung, 2 x 360 Impulse, 90° versetzt, 5V TTL - Speed/angle measurement, 2 x 360 impulses, 90° displaced, 5V TTL		Rechtsdrehung - CW-turn 
115391 ⁹	Drehzahl-/Drehwinkelmessung, RS485 - Speed/angle measurement, RS485		
	Auflösung Drehzahl - Speed resolution	min ⁻¹	1
	Genauigkeit Drehzahl - Speed accuracy	% v. E. - f. s.	1 ±1 Digit
	Auflösung Drehwinkel - Angle of rotation resolution	Grad - degree	0,25
	Ausgangssignal Drehzahl/ Drehwinkel - Output signal speed/ angle of rotation	Digits	±32.511
104097 ¹⁰	Drehzahlmessung, 1 x 60 Impulse, 5V TTL - Speed measurement, 1 x 60 impulses, 5V TTL		
41382	Kabeldose 12-polig Serie 581 - Female cable connector 12-pin series 581		
45598	Winkeldose 12-polig Serie 682 - Female angled connector 12-pin series 682		
10270	Anschlusskabel, 3 m, mit 12-pol. Kabeldose Serie 581 und freien Lötenden - Connection cable, 3 m, with 12-pin female cable connector series 581 and free soldered ends		
10345	Anschlusskabel winklig, 3 m, mit 12-pol. Kabeldose Serie 682 und freien Lötenden - Connection cable angled, 3 m, with 12-pin female cable connector series 682 and free soldered ends		

Option Kalibrierungen - Option Calibrations

Artikel-Nr. - Article-No.	Bezeichnung - Description	Stufen - Steps	Norm - Norm
400676	Linearitätsdiagramm - Linearity diagram	25%	Werksnorm - Factory standard
400664	Linearitätsdiagramm - Linearity diagram	10%	
400961	Werkskalibrierung - Proprietary calibration	3	VDI/VDE 2646
400700	Werkskalibrierung - Proprietary calibration	5	
400688	Werkskalibrierung - Proprietary calibration	8	
	DAkKS-Kalibrierung - DAkKS-Calibration		auf Anfrage - on request

⁸ Für DR-2212, DR-2212-P, DR-2212-R, DR-2212-R-P - For DR-2212, DR-2212-P, DR-2212-R, DR-2212-R-P

⁹ Für DR-2512, DR-2512-P, DR-2512-R, DR-2512-R-P - For DR-2512, DR-2512-P, DR-2512-R, DR-2512-R-P

¹⁰ Nenn Drehmoment ≥2000 N·m - Nominal torque ≥2000 N·m

Mechanische Abmessungen - Dimensions

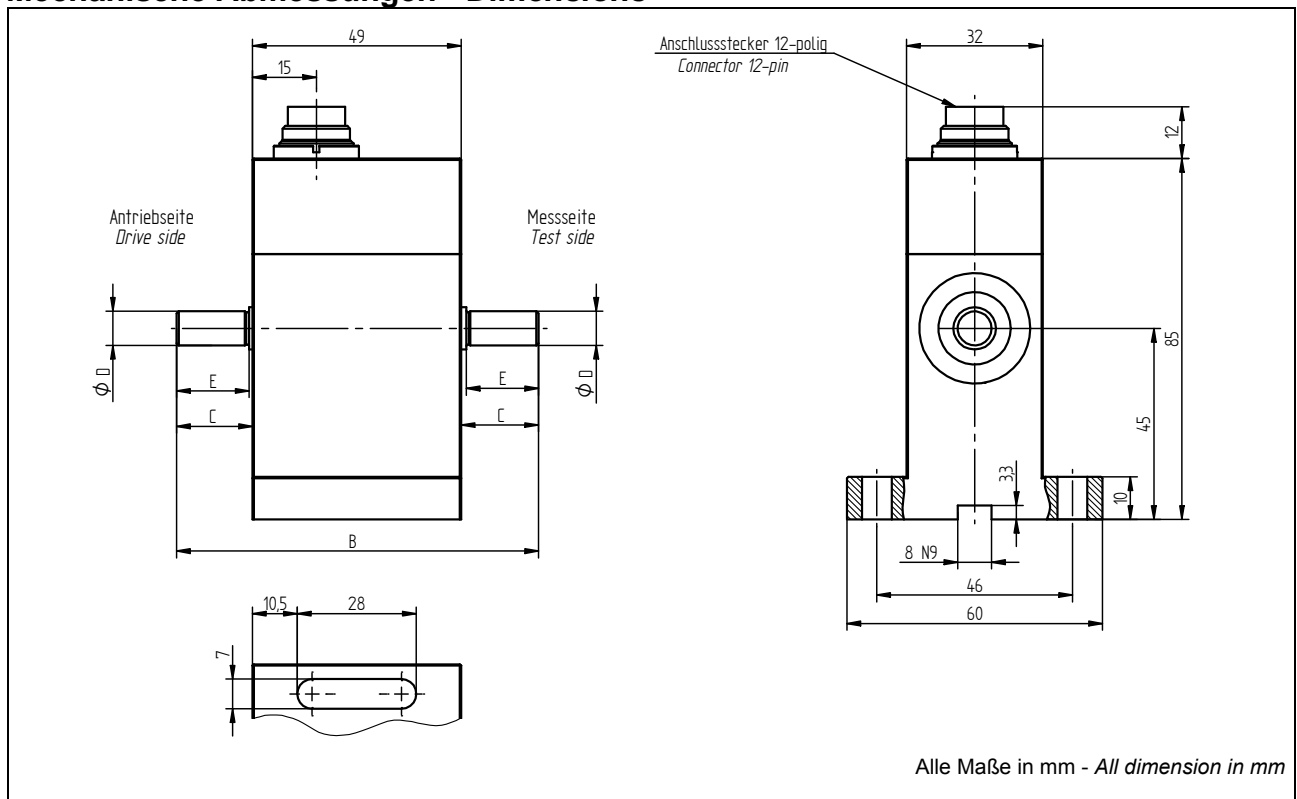

Nennmoment - Nominal Torque [N·m]	Abmessungen - Dimensions [mm]			
	B	C	Ø D	E
0,1 / 0,2 / 0,5 / 1	85	18	8 g6	17

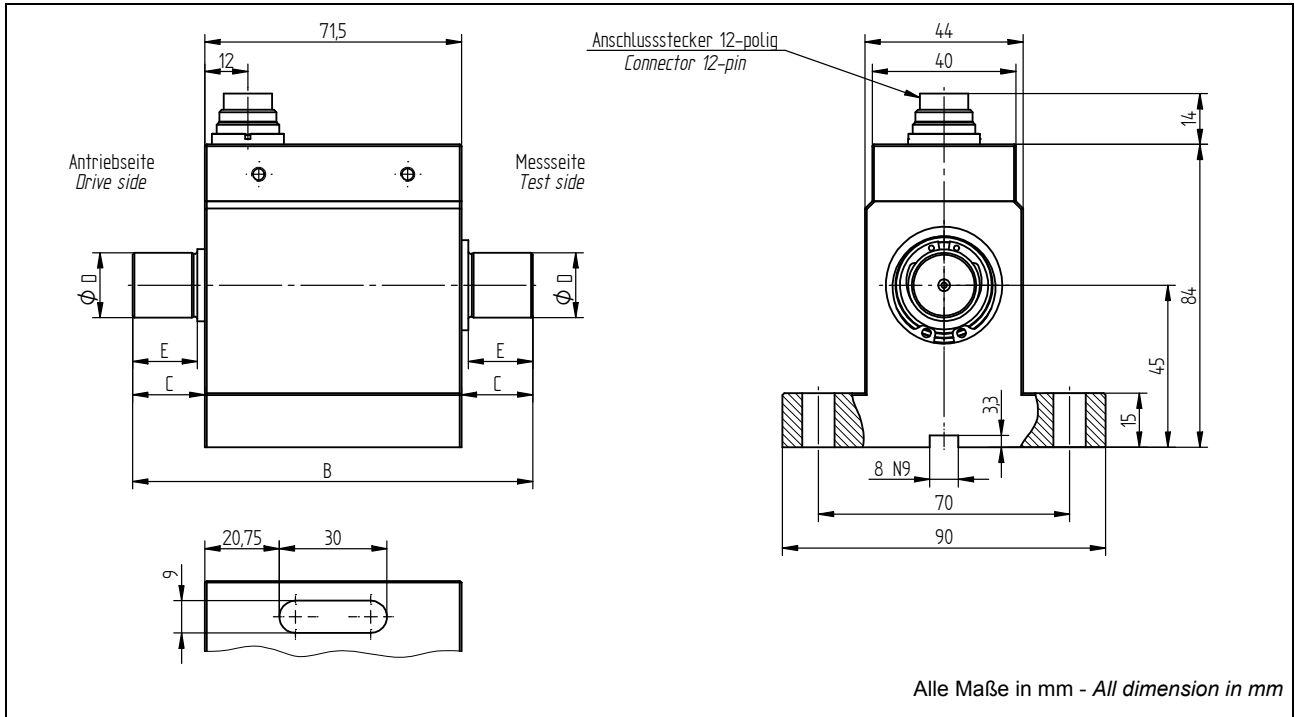

Nennmoment - Nominal Torque [N·m]	Abmessungen - Dimensions [mm]			
	B	C	ϕD	E
2 / 5	107,5	18	8 g6	17
10	107,5	18	10 g6	17
20 / 30	111,5	20	18 g6	18
50 / 100	147,5	38	18 g6	36

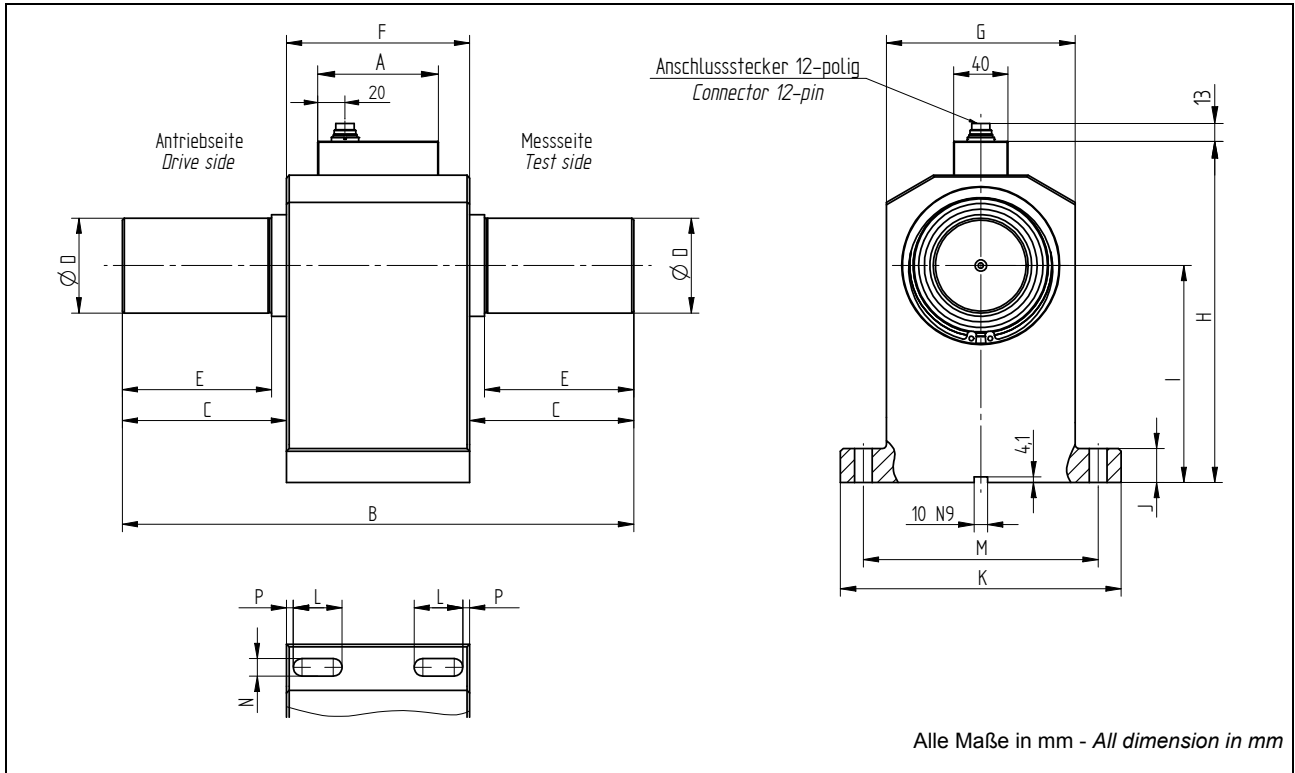

Nennmoment - Nominal Torque [N·m]	Abmessungen - Dimensions [mm]														
	A	B	C	ØD	E	F	G	H	I	J	K	L	M	N	P
200 / 500	89	217	43,5	32 g6	38	130	115	190,4	112	20	175	30	145	11	5
1000	89	262	66	50 g6	58	130	115	190,4	112	20	175	30	145	11	5
2000 / 5000	89	377	121	70 g6	110	135	139	251,5	160	25	207	36	173	13	5
10000 / 20000	89	470	140	110 g6	120	190	210	343	215	40	300	45	260	17	15

Ausführung Passfeder - Version Feather Key

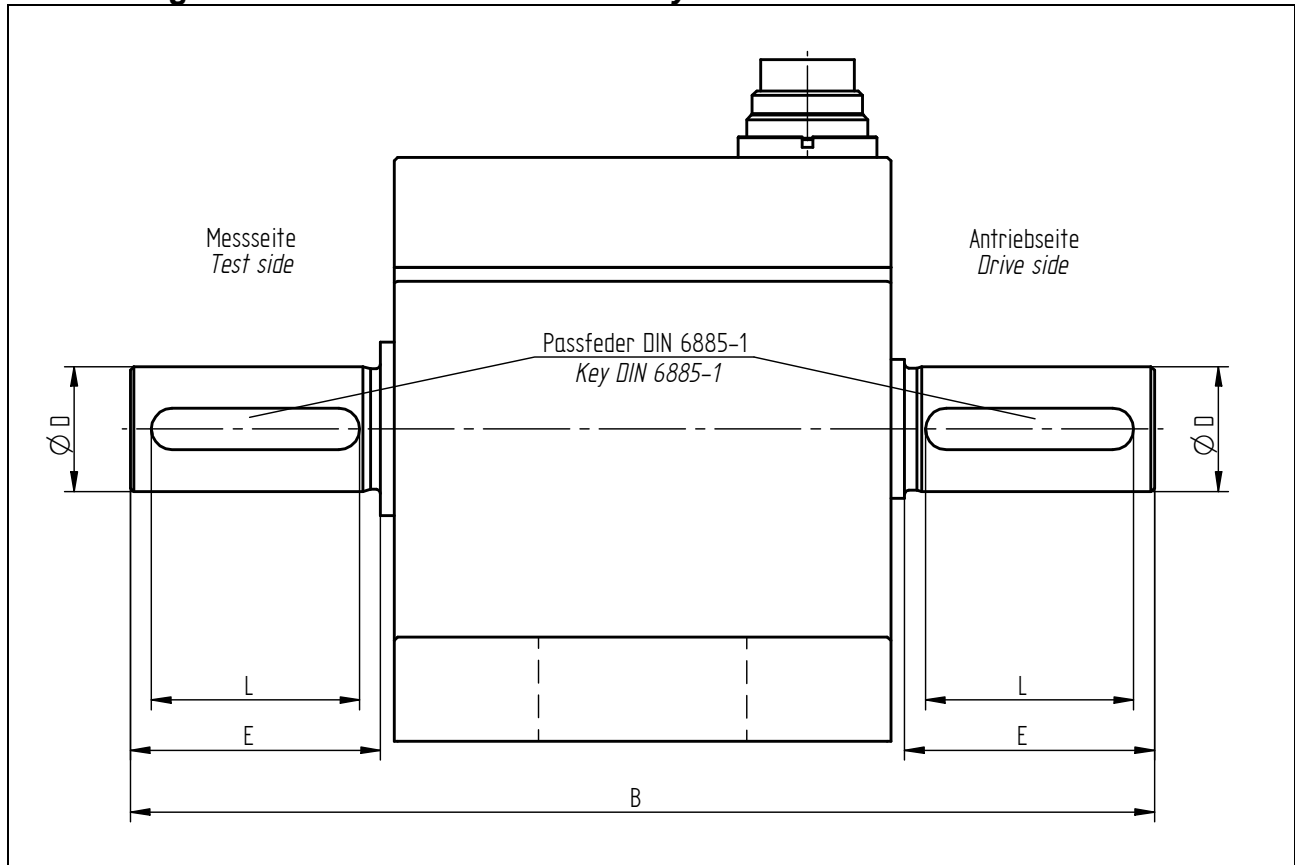

Nennmoment - Nominal Torque [N·m]	Abmessungen - Dimensions [mm]				
	B	Ø D	E	L	Passfeder - Feather Key ¹¹
0,1 / 0,2 / 0,5 / 1	85	8 g6	17	14	2 x 2 x 14
2 / 5	107,5	8 g6	17	14	2 x 2 x 14
10	107,5	10 g6	17	14	3 x 3 x 14
20 / 30	111,5	18 g6	18	14	6 x 6 x 14
50 / 100	147,5	18 g6	36	30	6 x 6 x 30
200 / 500	217	32 g6	38	36	10 x 8 x 36
1000	262	50 g6	58	50	14 x 9 x 50
2000 / 5000	377	70 g6	110	100	20 x 12 x 100
10000 / 20000	570	110 g6	170	160	28 x 16 x 160

¹¹ Passfeder berechnete Belastungsart, einseitig leichte Stöße - Calculated load type for feather key are single side light shocks