

Motion Reference Unit MRU-PD

- Ideal solution for survey
- Compatible with SBES/MBES
- IHO SP44 standard compliant
- 1 cm Position accuracy
- 5 cm Heave accuracy
- 10 cm Surge & Sway accuracy
- 0.05 deg Heading accuracy
- 0.03 deg Pitch and Roll accuracy
- 0.005 m/sec² Acceleration accuracy
- 0.0002 deg/sec Angular rate accuracy
- NMEA 0183 and TSS1 output data format

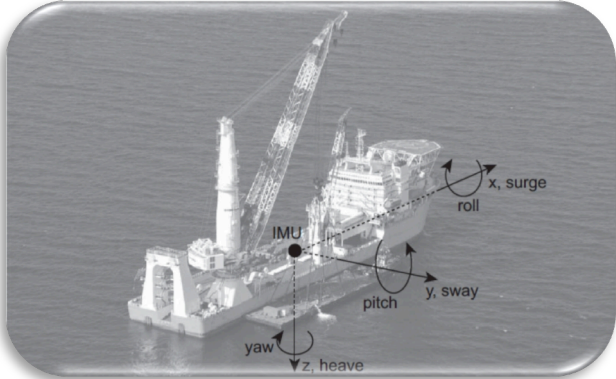

The Inertial Labs has developed professional version of **Motion Reference Units (MRU-PD)** to meet requirements from marine and hydrographic applications. **MRU-PD** is enhanced, high-performance strapdown Motion Sensor – affordable solution for survey, that determines Pitch & Roll, Heave, Sway, Surge, Accelerations, Angular rates, Heading, Velocity and Positions for any device on which it is mounted.



The Inertial Labs **MRU-PD Motion Reference Units** utilizes high precision, dual antenna GNSS receiver with DGPS and RTK positions accuracy, solid state 3-axes each of precision accelerometers, magnetometers, gyroscopes and barometric sensors to provide accurate Positions, Heading, Heave, Sway, Surge, Pitch and Roll of the device under measure. Integration of very low noise gyroscopes output provides high frequency, real-time measurement of the Vessel, Ships, Helidecks, ROV, Marine antennas, Cranes rotation about all three rotational axes.

Through a combination of proven sector expertise and a continued investment in technological innovation, Inertial Labs delivers the optimum balance of price and performance ratio solutions for its customers.

KEY FEATURES AND FUNCTIONALITY

- State-of-the-art algorithms for Vessels, Ships, Active Heave Compensators, Cranes, Helideck, ROV, AUV, DPS, Buoys, Echo Sounders, Offshore Platforms
- 0.03 deg RMS Pitch & Roll dynamic accuracy
- 5% or 5 cm RMS (whichever is greater) Heave accuracy
- 0.005 m/sec² linear acceleration accuracy
- NMEA 0183, TSS1 output data formats
- HYPACK, QINSY & Inertial Explorer software compatibility
- Velocity and Horizontal positions output
- Environmentally sealed (IP67), compact design



Our **MRUs** featuring developed few micro g Bias in-run stability Micro Electro Mechanical System (MEMS)-based accelerometers. New generation of Inertial Labs 1 deg/hr Bias in-run stability MEMS-based gyroscopes are an ideal solution for demanding marine applications, with their electronic nature negating the problems associated with expensive mechanical gyro solutions, as well as those based on fiber optic (FOG) technology. Inertial Labs MEMS gyroscopes set the standard for the industry, with our high-end **MRUs** featuring gyros that enable sector-leading accuracy and reliability standards.

Measured Parameters	MRU-PD Survey set	
Heave, Surge, Sway (% / cm)		✓
Pitch & Roll (deg)		✓
Precision Heading/Yaw (deg)		✓
Velocity (meters/sec)		✓
DGPS / RTK Positions (cm)		✓



MRU-PD Specifications

Parameter	Units	MRU-PD
Output signals	Heave, Surge, Sway, Heading/Yaw, Pitch, Roll, Positions, Velocity, Accelerations, Angular rates, Barometric data, PPS time	
Update rate	Hz	1 ... 200 (user settable)
Start-up time	sec	<1
Heave	Units	MRU-PD
Measurement range	meters	±300
Resolution	meters	0.01
Real time accuracy, RMS	% (meters)	5 (0.05)
Post Processing accuracy, RMS	% (meters)	3 (0.03)
Pitch and Roll	Units	MRU-PD
Range: Pitch, Roll	deg	±90, ±180
Angular Resolution	deg	0.005
Static Accuracy in whole Temperature Range	deg	0.02
Dynamic Accuracy	deg RMS	0.03
Post processing accuracy	deg RMS	0.01
Heading	Units	MRU-PD
Range	deg	0 to 360
Angular Resolution	deg	0.001
Real time Static and Dynamic Accuracy	deg	0.08 (2 meters baseline)
Real time Static and Dynamic Accuracy	deg	0.05 (4 meters baseline)
Post processing accuracy	deg RMS	<0.03
Positions, Velocity and Timestamps	Units	MRU-PD
Horizontal position accuracy (DGPS), RMS	meters	0.4
Horizontal position accuracy (RTK), RMS	meters	0.01
Post Processing Horizontal position accuracy (PPK), RMS	meters	0.005
GNSS Velocity accuracy, RMS	meters/sec	<0.03
IMU Velocity accuracy, RMS	meters/sec*√hr	<0.009
GNSS raw data rate	Hz	20
PPS accuracy	nano seconds	20
Gyroscopes	Units	MRU-PD
Measurement range	deg/sec	±450
Bias in-run stability (RMS, Allan Variance)	deg/hr	1
Noise density	deg/sec/√Hz	0.004
Accelerometers	Units	MRU-PD
Measurement range	g	±8
Bias in-run stability (RMS, Allan Variance)	mg	0.005
Noise density	mg/√Hz	0.015
Pressure	Units	MRU-PD
Measurement range	hPa	300 – 1100
Bias in-run stability (RMS, Allan Variance)	Pa	2
Noise density	Pa/√Hz	0.8
Environment	Units	MRU-PD
Operating temperature	deg C	-40 to +70
Storage temperature	deg C	-50 to +85
MTBF	hours	55,500
Electrical	Units	MRU-PD
Supply voltage	V DC	9 to 36
Power consumption	Watts	2.6
Output Interface	-	RS-232, RS-422
Output data format	-	NMEA 0183, TSS-1, Binary ASCII characters
Physical	Units	MRU-PD
Size	mm	120 x 50 x 53
Weight	gram	320

MRU-PD mechanical interface drawing

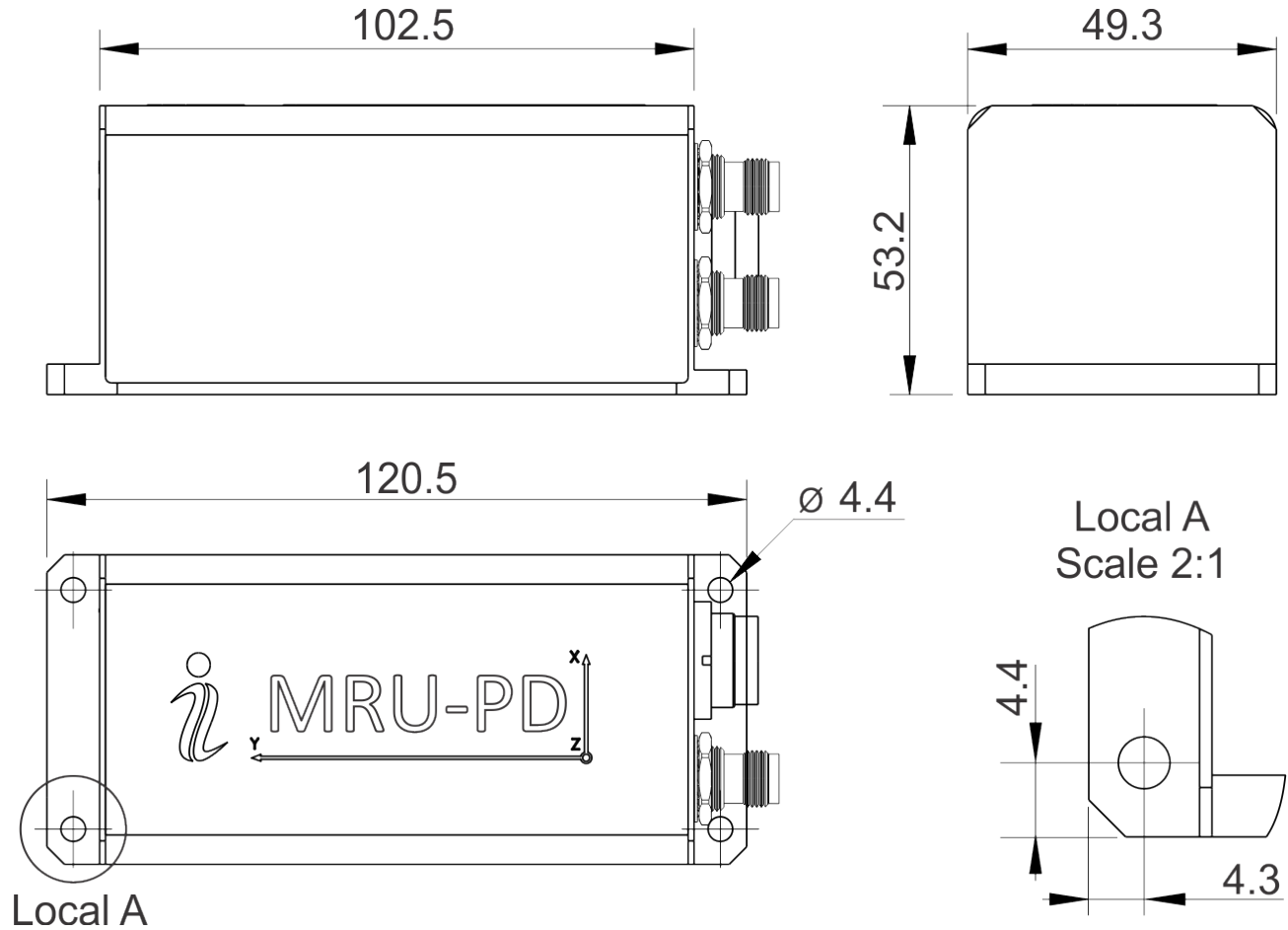

Notes:

1. All dimensions are in millimeters.
2. All dimensions within this drawing are subject to change without notice. Customers should obtain final drawings before designing any interface hardware.
3. Data connector type: Binder Series 723. Male receptacle, shielded, rear-mounting
4. GNSS connector type: TNC-Female